

XCalibur4101

Intel® Core™2 Duo Processor-Based Conduction- or Air-Cooled 6U cPCI Module

- › Intel Core 2 Duo processor-based 6U cPCI module
- › Conduction or air cooling
- › Autosense system/peripheral slot
- › Hot swap support
- › Up to 4 GB of DDR2 ECC SDRAM
- › 2 MB firmware hub flash (or 1 MB with redundancy)
- › 64 GB SSD
- › One front panel Gigabit Ethernet port
- › Two rear panel Gigabit Ethernet ports
- › Two PMC/XMC interfaces
- › Front and rear dual-head digital video
- › Complies with PICMG 2.0, 2.1, 2.3, 2.9, and 2.16
- › Linux BSP
- › Wind River VxWorks BSP
- › QNX Neutrino BSP
- › Green Hills INTEGRITY BSP
- › Windows drivers

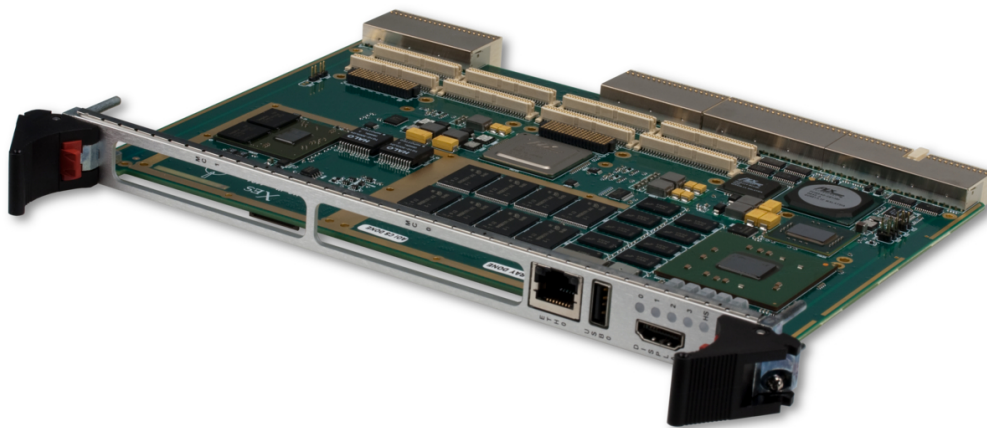

XCalibur4101

The XCalibur4101 is a 6U CompactPCI single-board computer featuring the Intel Core 2 Duo processor and a ruggedized, conduction- or air-cooled design, making it ideal for today's rugged embedded computing applications.

The XCalibur4101 provides up to 4 GB of DDR2 ECC SDRAM, 2 MB firmware hub flash (or 1 MB with redundancy), and two PMC/XMC slots. The XCalibur4101 also supports Gigabit Ethernet, I²C, USB, PMC I/O, XMC I/O, DVI dual-head graphics, and RS-232/RS-422/RS-485 serial ports out the J3 and J5 connectors.

The XCalibur4101 is a ruggedized, high-performance, feature-rich solution to support the next generation of rugged embedded applications. Linux, Wind River VxWorks, QNX Neutrino, and Green Hills INTEGRITY Board Support Packages (BSPs), as well as Windows drivers, are available.

X-ES

Extreme Engineering Solutions

...Always Fast

Extreme Engineering Solutions

3225 Deming Way, Suite 120 • Middleton, WI 53562

Phone: 608.833.1155 • Fax: 608.827.6171

sales@xes-inc.com • <http://www.xes-inc.com>

Processor

- Intel Core 2 Duo at up to 1.8 GHz
- 200 MHz (800 MT/s) FSB
- Up to 6 MB of L2 cache

Memory

- Up to 4 GB of DDR2-400 ECC SDRAM
- 2 MB firmware hub flash (or 1 MB with redundancy)

cPCI

- 66 MHz 64-bit PCI interface to J1 and J2
- PICMG 2.1 (hot swap support)
- PICMG 2.3 (PMC I/O to P3 and P5)
- PICMG 2.9 (dedicated IPMI controller)
- PICMG 2.16 (two 10/100/1000BASE-T Ethernet ports)

PMC

- PCI-X (32/64-bit, 66/100 MHz)
- PCI (32/64-bit, 33/66 MHz)

XMC (VITA 42.3)

- x1, x2, x4, x8 links supported
- Full-duplex 5 GT/s lanes

Graphics

- Front and rear panel DVI
- Resolutions supported: up to 2560x1600 RP and up to 1920x1200 FP, or two RP 1920x1200 each

On-board SATA Storage

- 64 GB solid-state disk

Interfaces

- Gigabit Ethernet
- RS-232/RS-422/RS-485 serial
- USB 2.0
- SATA
- DVI

Software Support

- Linux BSP
- Wind River VxWorks BSP
- QNX Neutrino BSP
- Green Hills INTEGRITY
- Windows drivers

Environmental Requirements

Contact factory for appropriate board configuration based on environmental requirements.

- Supported ruggedization levels (see chart below): 1, 3, 5
- Conformal coating available as an ordering option

Power Requirements

- Maximum power consumption: 45 W (with 1.8-GHz processor) 36 W (with 1.2-GHz processor)

Supported Ruggedization Level	Level 1	Level 3	Level 5
Cooling Method	Standard Air-Cooled	Rugged Air-Cooled	Conduction-Cooled
Operating Temperature	0 to +55 °C ambient (300 LFM)	-40 to +70 °C (600 LFM)	-40 to +85 °C (board rail surface)
Storage Temperature	0 to +85 °C ambient	-40 to +105 °C ambient	-55 to +105 °C ambient
Vibration	0.002 g ² /Hz, 5 to 2000 Hz	0.04 g ² /Hz (maximum), 5 to 2000 Hz	0.1 g ² /Hz (maximum), 5 to 2000 Hz
Shock	20 g, 11 ms sawtooth	30 g, 11 ms sawtooth	40 g, 11 ms sawtooth
Humidity	0% to 95% non-condensing	0% to 95% non-condensing	0% to 95% non-condensing

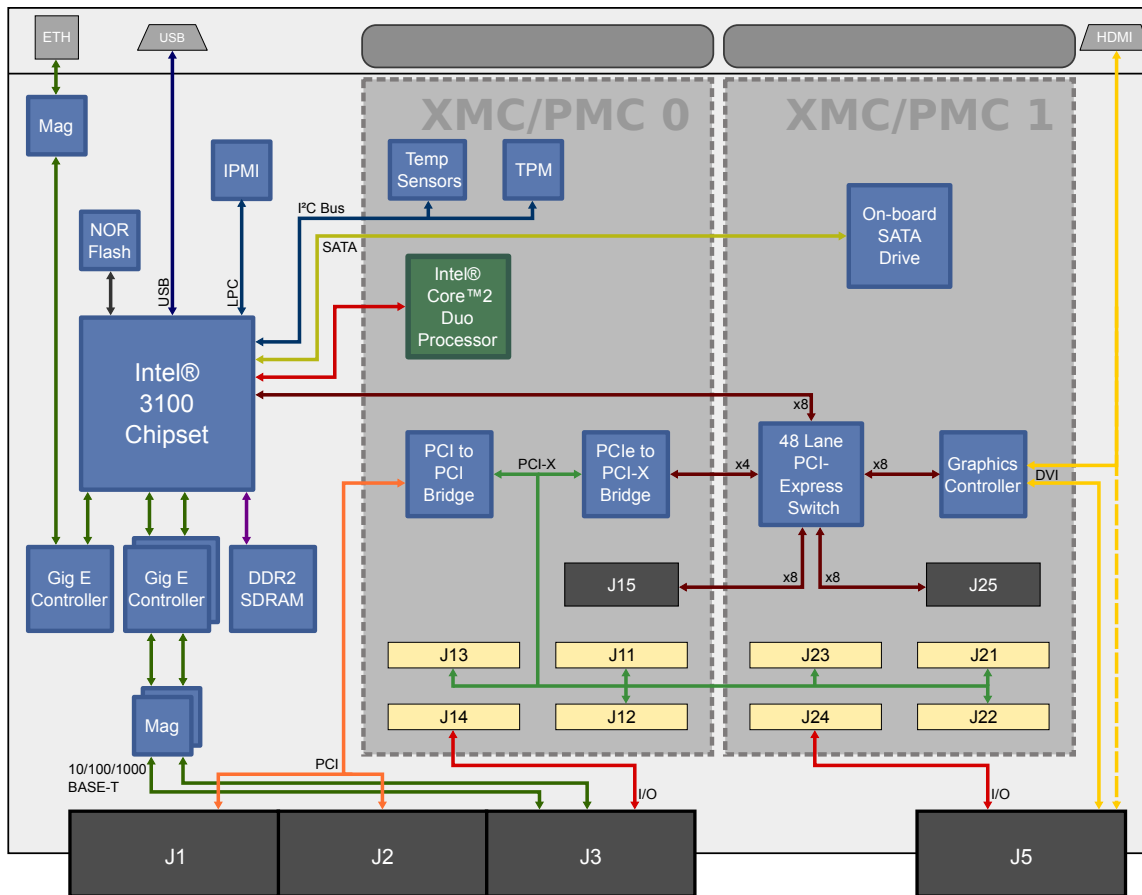

XCalibur4101

