

XPedite5501

Freescale Dual-Core QorIQ™ P2020 Processor-Based Conduction-Cooled PMC/XMC Module

- ▶ Freescale QorIQ P2020 processor with dual PowerPC e500 cores at up to 1.2 GHz
- ▶ Conduction cooling
- ▶ Extended shock and vibration tolerance
- ▶ Up to 4 GB of DDR3-800 ECC SDRAM
- ▶ x4 PCI Express or serial RapidIO interface to P15
- ▶ PCI PrPMC interface
- ▶ Two Gigabit Ethernet ports to P14 or P16
- ▶ Two RS-232/RS-422/RS-485 serial ports to P14 or P16
- ▶ USB 2.0 port
- ▶ Up to 256 MB of NOR flash (with redundancy)
- ▶ Up to 8 GB of NAND flash
- ▶ Detachable front panel for development
- ▶ Linux BSP
- ▶ Wind River VxWorks BSP
- ▶ QNX Neutrino BSP
- ▶ Green Hills INTEGRITY BSP



XPedite5501

The XPedite5501 is a PrPMC/XMC single board computer targeting the Freescale QorIQ P2020 processor. Hardware options range from commercial/air-cooled to full-military conduction-cooled solutions. With dual PowerPC e500 cores running at up to 1.2 GHz, the P2020 delivers enhanced performance and efficiency for today's network information processing and other embedded computing applications.

Complementing processor performance, the XPedite5501 features up to 4 GB of DDR3-800 ECC SDRAM. A configurable SerDes interface (PCI Express or serial RapidIO) to the XMC connector and a conventional PCI interface to the PMC connectors provide ample bandwidth to the P2020. Two Gigabit Ethernet ports, a USB 2.0 port, and two RS-232/RS-422/RS-485 ports are routed to P14 or P16 for additional system flexibility. A detachable front panel provides one Gigabit Ethernet port and one RS-232 serial port for development.

The XPedite5501 provides a high-performance, feature-rich solution for current and future generations of embedded applications. Additionally, for customers seeking a max power of just 8 W, the XPedite5501 can be designed with the Freescale P1020 processor. Operating system support packages for the XPedite5501 include Wind River VxWorks, QNX Neutrino, Green Hills INTEGRITY, and Linux 2.6.

X-ES

Extreme Engineering Solutions

...Always Fast

Extreme Engineering Solutions

3225 Deming Way, Suite 120 • Middleton, WI 53562
 Phone: 608.833.1155 • Fax: 608.827.6171
 sales@xes-inc.com • <http://www.xes-inc.com>

Processor

- Freescale QorIQ P2020 processor
- Dual PowerPC e500 cores at up to 1.2 GHz
- 512 kB of shared L2 cache

Memory

- Up to 4 GB DDR3-800 SDRAM
- Up to 256 MB of NOR flash (with redundancy)
- Up to 8 GB of NAND flash

PrPMC Interface

- 66/33-MHz PCI
- 32-bit bus interface

P15 XMC Interface

- x4 configurable PCI Express or Serial RapidIO

P14/P16 PMC/XMC Interface

- Two Gigabit Ethernet ports
- Two RS-232/RS-422/RS-485 ports
- 3.3V GPIO
- One USB 2.0 port

Software Support

- Linux BSP
- Wind River VxWorks BSP
- QNX Neutrino BSP
- Green Hills INTEGRITY BSP

Physical Characteristics

- Conduction-cooled PMC/XMC form factor
- Dimensions: 143.75 mm x 74 mm

Environmental Requirements

Contact factory for appropriate board configuration based on environmental requirements.

- Supported ruggedization levels (see chart below): 1, 3, 5
- Conformal coating available as an ordering option

Power Requirements

- Maximum power consumption:
15 W with P2020 at 1.2 GHz at 125°C
8 W (est.) with P1020 at 800 MHz at 125°C

Supported Ruggedization Level	Level 1	Level 3	Level 5
Cooling Method	Standard Air-Cooled	Rugged Air-Cooled	Conduction-Cooled
Operating Temperature	0 to +55 °C ambient (300 LFM)	-40 to +70 °C (600 LFM)	-40 to +85 °C (board rail surface)
Storage Temperature	0 to +85 °C ambient	-40 to +105 °C ambient	-55 to +105 °C ambient
Vibration	0.002 g ² /Hz, 5 to 2000 Hz	0.04 g ² /Hz (maximum), 5 to 2000 Hz	0.1 g ² /Hz (maximum), 5 to 2000 Hz
Shock	20 g, 11 ms sawtooth	30 g, 11 ms sawtooth	40 g, 11 ms sawtooth
Humidity	0% to 95% non-condensing	0% to 95% non-condensing	0% to 95% non-condensing

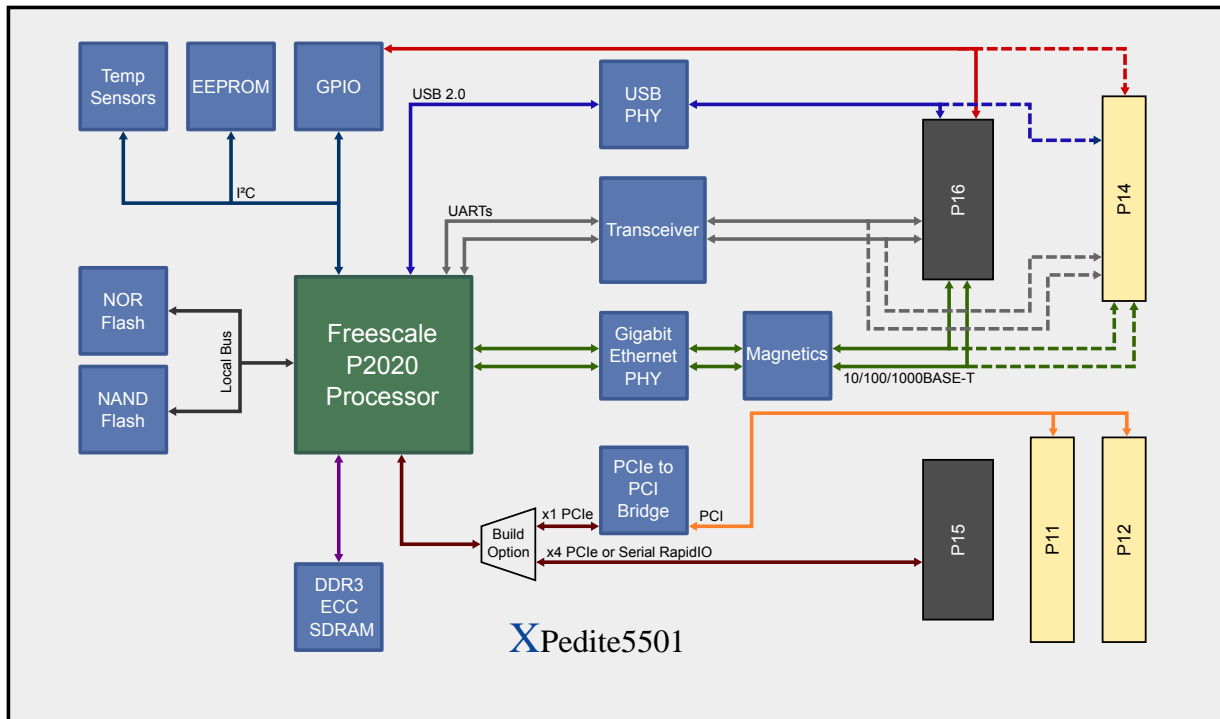

XPedite5501

