

# XCalibur4341

**Not Recommended  
for New Designs**

Intel® Core™ i7 Processor-Based Conduction- or Air-Cooled 6U VPX Module

Please see XCalibur4540 or  
XCalibur4440

- ▶ Intel® Core™ i7-610E, -620LE, -620UE, and -660UE processors
- ▶ Dual-core with Hyper-Threading Technology
- ▶ 6U VPX module
- ▶ OpenVPX™ standards-based
- ▶ Conduction or air cooling
- ▶ Up to 8 GB DDR3-1066 ECC SDRAM in two channels
- ▶ 32 MB NOR boot flash
- ▶ Up to 128 GB of NAND flash
- ▶ Five Gigabit Ethernet ports
- ▶ x8 Gen2 PCI Express ports from switch to CPU and XMC sites
- ▶ Four x4 Gen2 PCI Express ports from switch to backplane
- ▶ Two DVI-D graphics ports
- ▶ Audio line I/O port
- ▶ Four SATA ports on backplane
- ▶ Three USB 2.0 ports (one to front panel and two to backplane)
- ▶ Two RS-232/422/485 serial ports
- ▶ Two PrPMC/XMC interfaces
- ▶ Linux BSP
- ▶ Wind River VxWorks BSP
- ▶ QNX Neutrino BSP
- ▶ Green Hills INTEGRITY BSP
- ▶ Microsoft Windows drivers

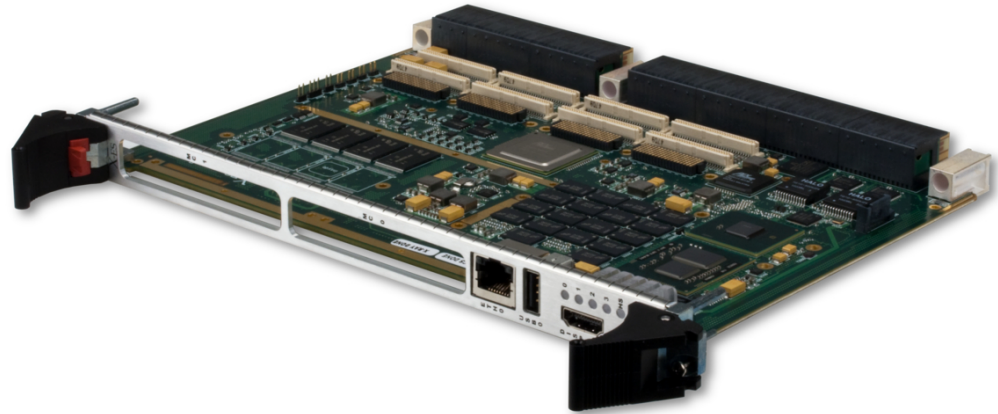

## XCalibur4341

The XCalibur4341 is a high-performance, 6U VPX, multiprocessing, single board computer that is ideal for ruggedized systems requiring high bandwidth processing and low power consumption. With the Intel® Core™ i7 processor and Intel® QM57 chipset, the XCalibur4341 delivers enhanced performance and efficiency for today's network information processing and embedded computing applications.

The XCalibur4341 provides two separate channels of up to 8 GB DDR3-1066 ECC SDRAM, two PrPMC/XMC slots, 32 MB of NOR flash and up to 128 GB of NAND flash. The XCalibur4341 also supports five Gigabit Ethernet ports, two DVI-D graphics ports, audio, I<sup>2</sup>C, PMC I/O, XMC I/O, and RS-232/422/485 serial ports out the front panel and/or backplane connector.

The XCalibur4341 is a powerful, feature-rich solution for the next generation of compute-intensive embedded applications. Operating system support for Wind River VxWorks, Microsoft Windows, QNX Neutrino, and Linux is available.

# X-ES

Extreme Engineering Solutions

*...Always Fast*

### Extreme Engineering Solutions

3225 Deming Way, Suite 120 • Middleton, WI 53562  
Phone: 608.833.1155 • Fax: 608.827.6171  
sales@xes-inc.com • <http://www.xes-inc.com>

**Processor**

- Intel® Core™ i7 processor operating at 2.53, 2.0, 1.06, or 1.33 GHz
- Dual-core with Hyper-Threading Technology
- Intel® QM57 chipset
- Dual-channel integrated memory controller
- Integrated graphics controller
- 4 MB of shared cache

**Memory**

- Up to 8 GB DDR3-1066 ECC SDRAM in two channels
- 32 MB of NOR flash
- Up to 128 GB of NAND flash
- 16 kB I<sup>2</sup>C EEPROM

**Graphics**

- Integrated high-performance 3D graphics controller
- Two DVI-D (one to front panel, one to P6)

**VPX**

- OpenVPX™ (VITA 65)
- Four x4 Gen2 PCIe ports to P1
- Two 1000BASE-BX Ethernet ports to P4
- Two 10/100/1000BASE-T Ethernet ports
- PMC and XMC I/O to P3, P4, P5, P6, mapping P3w1P4-P64s+X12d+X8d

**PrPMC**

- PCI-X (64/32-bit, 100/66 MHz)
- PCI (64/32-bit, 66/33 MHz)

**XMC**

- x8 Gen2 PCIe ports to J15 and J25
- One SATA port capable of 3.0 Gb/s to J26

**Front Panel I/O (Optional)**

- One HDMI video interface
- One 10/100/1000BASE-T Ethernet port
- One USB 2.0 port
- General-purpose LEDs

**Back Panel**

- Two RS-232/422/485 serial ports
- Two 10/100/1000BASE-T Ethernet ports
- Two 1000BASE-BX Ethernet ports
- Four SATA ports capable of 3.0 Gb/s
- PMC I/O
- Four USB 2.0 ports
- Audio line I/O port

**Software Support**

- Linux BSP
- Wind River VxWorks BSP
- QNX Neutrino BSP
- Greens Hills INTEGRITY BSP
- Microsoft Windows drivers

**Environmental Requirements**

- Contact factory for appropriate board configuration based on environmental requirements.
- Supported ruggedization levels (see chart below): 1, 3, 5
  - Conformal coating available as an ordering option

**Power Requirements**

- Power will vary based on configuration and usage. Please consult factory.

Ruggedization Level	Level 1	Level 3	Level 5
Cooling Method	Standard Air-Cooled	Rugged Air-Cooled	Conduction-Cooled
Operating Temperature	0 to +55°C ambient (300 LFM)	-40 to +70°C (600 LFM)	-40 to +85°C (board rail surface)
Storage Temperature	-40 to +85°C ambient	-55 to +105°C ambient	-55 to +105°C ambient
Vibration	0.002 g <sup>2</sup> /Hz, 5 to 2000 Hz	0.04 g <sup>2</sup> /Hz (maximum), 5 to 2000 Hz	0.1 g <sup>2</sup> /Hz (maximum), 5 to 2000 Hz
Shock	20 g, 11 ms sawtooth	30 g, 11 ms sawtooth	40 g, 11 ms sawtooth
Humidity	0% to 95% non-condensing	0% to 95% non-condensing	0% to 95% non-condensing

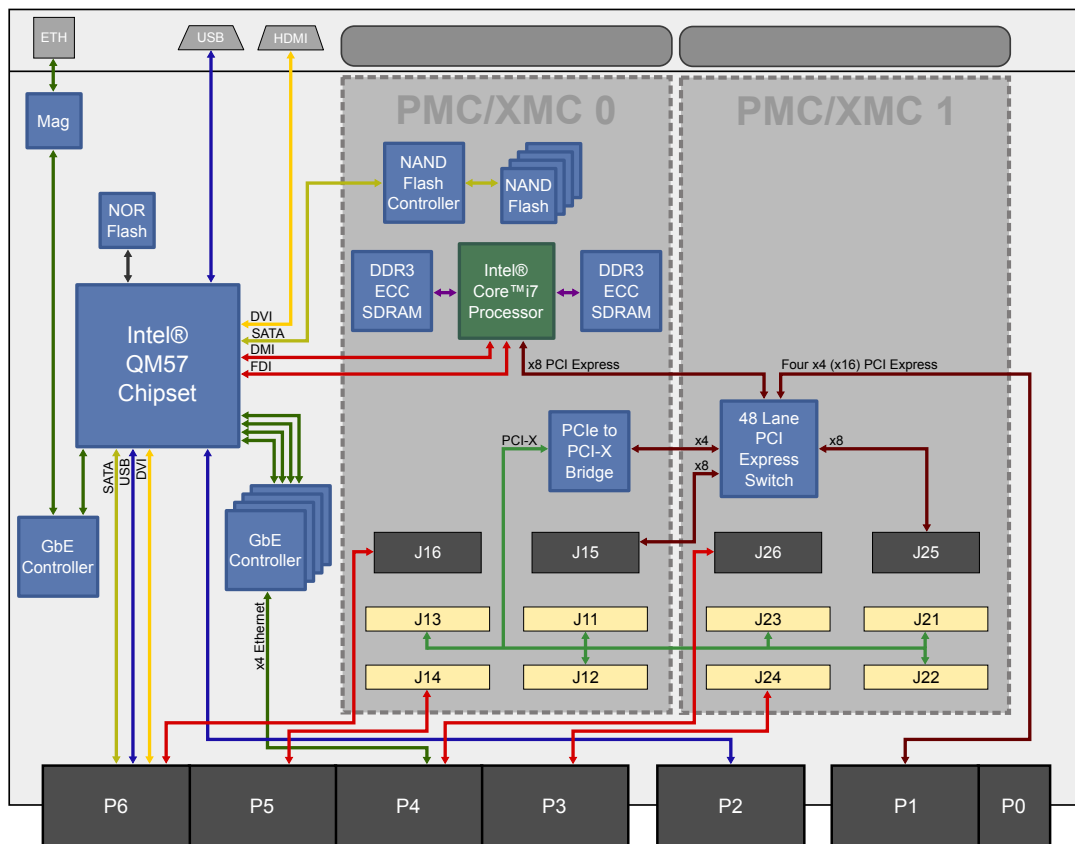

XCalibur4341

