

XPedite5301

**Not Recommended
for New Designs**

Freescale Dual-Core MPC8572E PowerQUICC™ III Processor-Based Conduction-Cooled XMC/PMC Module **Please see XPedite6101**

- › Freescale MPC8572E PowerQUICC™ III processor with dual PowerPC e500 cores at up to 1.5 GHz
- › Conduction cooling
- › Extended shock and vibration tolerance
- › Up to 2 GB (1 GB each) of DDR2-800 ECC SDRAM in two channels
- › x4 PCI Express or Serial RapidIO interface to P15
- › PCI PrPMC interface
- › Two Gigabit Ethernet ports to P14 or P16
- › Two RS-232/422/485 serial ports to P14 or P16
- › Up to 256 MB of NOR flash (with redundancy)
- › Up to 4 GB of NAND flash
- › Detachable front panel for development
- › Linux BSP
- › Wind River VxWorks BSP
- › QNX Neutrino BSP
- › Green Hills INTEGRITY BSP

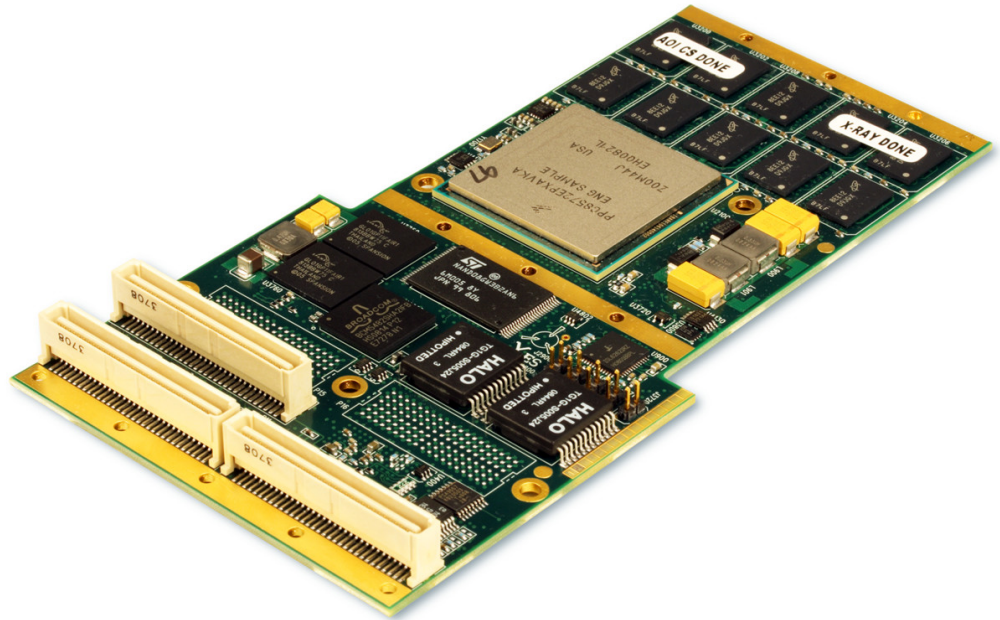

XPedite5301

The XPedite5301 is a conduction-cooled XMC mezzanine module based on the Freescale MPC8572E PowerQUICC™ III processor. With dual PowerPC e500 cores running at up to 1.5 GHz, the MPC8572E delivers enhanced performance and efficiency for today's network information processing and other embedded computing applications.

Complementing processor performance, the XPedite5301 features two separate channels of up to 1 GB each of DDR2-800 ECC SDRAM. A software-configurable SerDes interface (PCI Express or Serial RapidIO) to the XMC connector and a conventional PCI interface to the PMC connectors provide ample bandwidth to the MPC8572E. Two Gigabit Ethernet ports and two RS-232/422/485 ports are routed to P14 or P16 for additional system flexibility. A detachable front panel provides one 10/100/1000BASE-T Ethernet port and one RS-232 serial port for development.

The XPedite5301 provides a high-performance, feature-rich solution for current and future generations of embedded applications. Operating system support packages for the XPedite5301 include Wind River VxWorks, QNX Neutrino, Green Hills INTEGRITY, and Linux 2.6.

X-ES

Extreme Engineering Solutions

...Always Fast

Extreme Engineering Solutions

3225 Deming Way, Suite 120 • Middleton, WI 53562
 Phone: 608.833.1155 • Fax: 608.827.6171
 sales@xes-inc.com • <http://www.xes-inc.com>

Processor

- Freescale MPC8572E PowerQUICC™ III processor
- Dual PowerPC e500 cores at up to 1.5 GHz
- 1 MB of shared L2 cache

Memory

- Up to 2 GB (1 GB each) of DDR2-800 ECC SDRAM, in two channels
- Up to 256 MB of NOR flash (with redundancy)
- Up to 4 GB of NAND flash

PrPMC Interface

- 66/33 MHz PCI
- 32-bit bus interface

P15 XMC Interface

- x4 configurable PCI Express or Serial RapidIO

P14/P16 XMC/PMC Interface

- Two 10/100/1000BASE-T Ethernet ports
- Two RS-232/422/485 serial ports
- 3.3 V GPIO

Software Support

- Linux BSP
- Wind River VxWorks BSP
- QNX Neutrino BSP
- Green Hills INTEGRITY BSP

Physical Characteristics

- Conduction-cooled XMC/PMC form factor
- Dimensions: 143.75 mm x 74 mm, 10 mm stacking height

Environmental Requirements

Contact factory for appropriate board configuration based on environmental requirements.

- Supported ruggedization levels (see chart below): 1, 3, 5
- Conformal coating available as an ordering option

Power Requirements

- Maximum power consumption: 26 W (with 1.5 GHz processor), 23 W (with 1.33 GHz processor)

Ruggedization Level	Level 1	Level 3	Level 5
Cooling Method	Standard Air-Cooled	Rugged Air-Cooled	Conduction-Cooled
Operating Temperature	0 to +55°C ambient (300 LFM)	-40 to +70°C (600 LFM)	-40 to +85°C (board rail surface)
Storage Temperature	-40 to +85°C ambient	-55 to +105°C ambient	-55 to +105°C ambient
Vibration	0.002 g ² /Hz, 5 to 2000 Hz	0.04 g ² /Hz (maximum), 5 to 2000 Hz	0.1 g ² /Hz (maximum), 5 to 2000 Hz
Shock	20 g, 11 ms sawtooth	30 g, 11 ms sawtooth	40 g, 11 ms sawtooth
Humidity	0% to 95% non-condensing	0% to 95% non-condensing	0% to 95% non-condensing

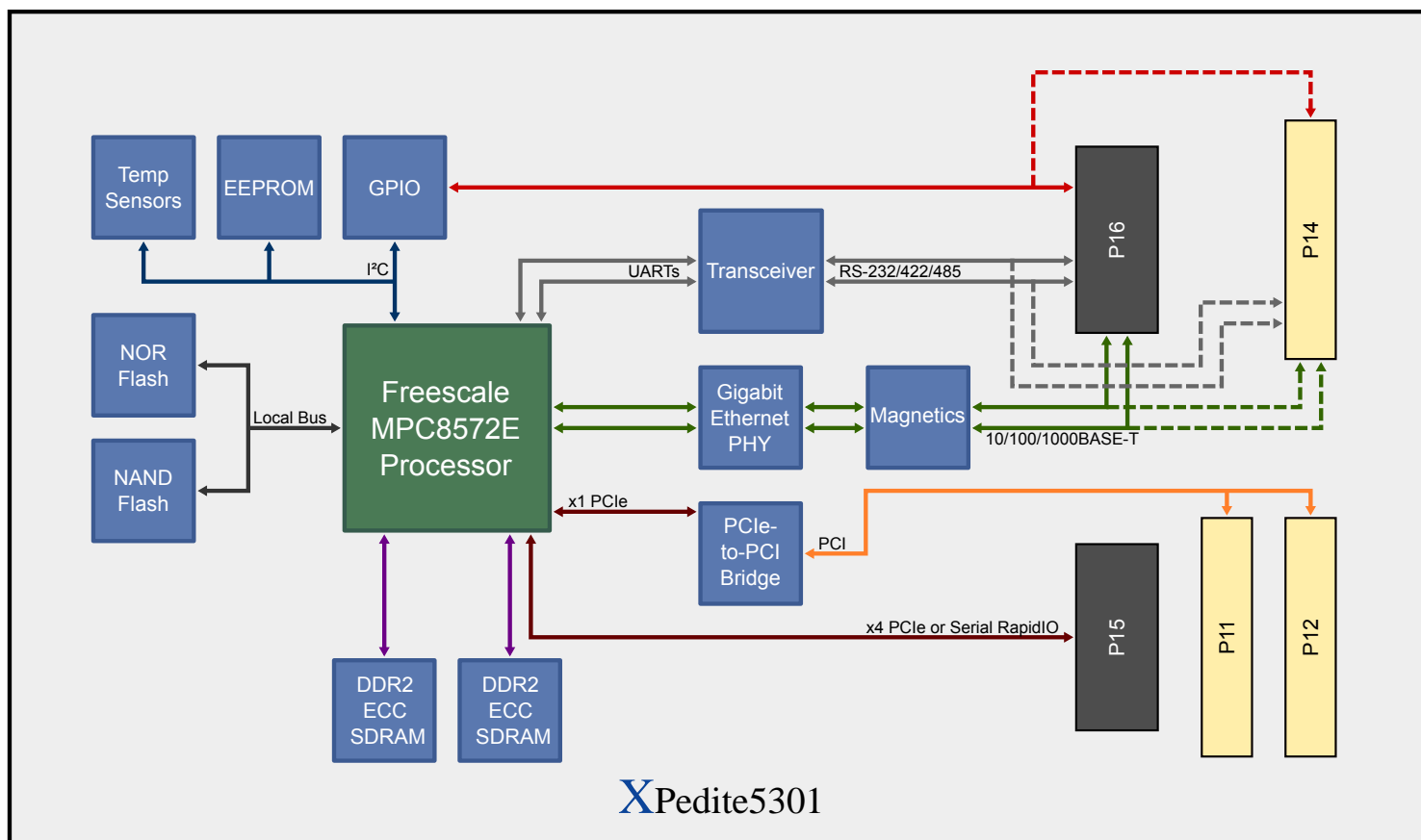

XPedite5301