

# XPedite5101

**End of Life**

NXP MPC8640D Processor-Based Conduction- or Air-Cooled XMC/PMC Mezzanine Module

Please contact X-ES Sales

- › NXP MPC8640D processor with dual PowerPC e600 cores at up to 1.25 GHz
- › Conduction or air cooling
- › Extended shock and vibration tolerance
- › Up to 4 GB (2 GB each) of DDR2-533 ECC SDRAM in two channels
- › x8 PCI Express to P15
- › 32-bit, 66 MHz PCI to P11/P12
- › Two Gigabit Ethernet ports to P14 or P16
- › Two RS-232/422/485 serial ports to P14 or P16
- › Up to 256 MB of NOR flash (with redundancy)
- › Up to 4 GB of NAND flash
- › Detachable front panel for development
- › Wind River VxWorks BSP
- › QNX Neutrino BSP
- › Green Hills INTEGRITY BSP
- › Linux BSP



## XPedite5101

The XPedite5101 is a conduction-cooled XMC/PrPMC mezzanine module based on the NXP (formerly Freescale) MPC8640D processor. With dual PowerPC e600 cores running at up to 1.25 GHz, the MPC8640D delivers enhanced performance and efficiency for today's network information processing and other embedded computing applications.

Complementing processor performance, the XPedite5101 features two separate channels of up to 2 GB each of DDR2-533 ECC SDRAM. A x8 PCI Express interface to the P15 XMC connector and a conventional 32-bit, 66 MHz PCI interface to the P11/P12 PMC connectors provides ample I/O to the MPC8640D. Two Gigabit Ethernet ports and two RS-232/422/485 ports are routed to P14 or P16 for additional system flexibility. A detachable front panel provides one Gigabit Ethernet port and one RS-232 serial port for development.

The XPedite5101 provides a high-performance, feature-rich solution for current and future generations of embedded applications. Operating system support packages for the XPedite5101 include Wind River VxWorks, QNX Neutrino, Green Hills INTEGRITY, and Linux 2.6.

# X-ES

Extreme Engineering Solutions

*...Always Fast*

### Extreme Engineering Solutions

9901 Silicon Prairie Parkway • Verona, WI 53593  
 Phone: 608.833.1155 • Fax: 608.827.6171  
 sales@xes-inc.com • <https://www.xes-inc.com>

**Processor**

- NXP (formerly Freescale) MPC8640D processor
- Dual PowerPC e600 cores at up to 1.25 GHz
- 1 MB of L2 cache per core
- Integrated Altivec
- IEEE 754-compliant 64-bit Floating-Point Unit

**Memory**

- Up to 4 GB (2 GB each) of DDR2-533 ECC SDRAM in two channels
- Up to 256 MB NOR flash
- Up to 4 GB NAND flash
- 16 kB SEEPROM

**P11/P12 PrPMC Interface**

- 66/33 MHz PCI
- 32-bit bus interface

**P15 XMC Interface**

- x8 PCI Express (VITA 42.3)

**P14/P16 PMC/XMC Interface**

- Two Gigabit Ethernet ports
- Two RS-232/422/485 ports
- Four 3.3 V GPIO pins

**Front Panel I/O**

- Removable front bezel module (optional)
- Easy access to RS-232, Ethernet, and JTAG ports for development purposes

**RTC**

- M41T00 I<sup>2</sup>C timekeeper
- 60 hour clock retention

**Software**

- Wind River VxWorks BSP
- QNX Neutrino BSP
- Green Hills INTEGRITY BSP
- Linux BSP

**Physical Characteristics**

- Conduction-cooled PMC/XMC form factor
- Dimensions: 143.75 mm x 74 mm, 10 mm stacking height

**Environmental Requirements**

Contact factory for appropriate board configuration based on environmental requirements.

- Supported ruggedization levels (see chart below): 5
- Conformal coating available as an ordering option

**Power Requirements**

MPC8640D at 1.067 GHz, DDR2-533, all interfaces active

- 30 W per board

Ruggedization Level	Level 1	Level 3	Level 5
Cooling Method	Standard Air-Cooled	Rugged Air-Cooled	Conduction-Cooled
Operating Temperature	0 to +55°C ambient (300 LFM)	-40 to +70°C (600 LFM)	-40 to +85°C (board rail surface)
Storage Temperature	-40 to +85°C ambient	-55 to +105°C ambient	-55 to +105°C (maximum)
Vibration	0.002 g <sup>2</sup> /Hz (maximum), 5 to 2000 Hz	0.04 g <sup>2</sup> /Hz (maximum), 5 to 2000 Hz	0.1 g <sup>2</sup> /Hz (maximum), 5 to 2000 Hz
Shock	20 g, 11 ms sawtooth	30 g, 11 ms sawtooth	40 g, 11 ms sawtooth
Humidity	0% to 95% non-condensing	0% to 95% non-condensing	0% to 95% non-condensing

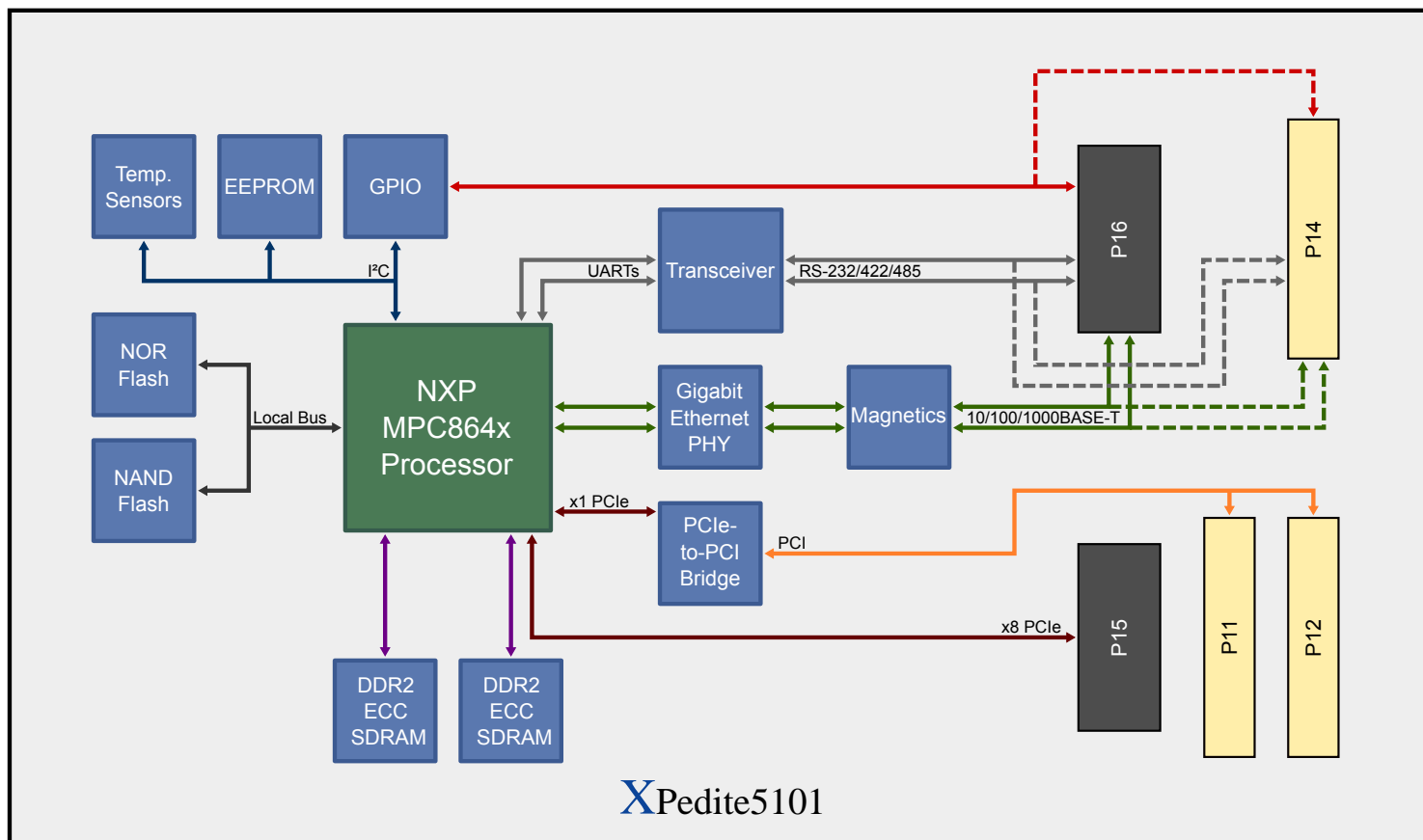

XPedite5101