

# XPedite5102

**Not Recommended  
for New Designs**

Dual-Core Freescale MPC8640D Processor-Based Short-Form XMC Module with Dual Gigabit Ethernet **Please contact X-ES Sales**

- › Freescale MPC8640D with dual e600 cores at up to 1.25 GHz
- › Two rear panel Gigabit Ethernet interfaces
- › x8 PCI Express on P15
- › x4 PCI Express on P16
- › Up to 4 GB of DDR2-533 SDRAM in two channels
- › 1 MB L2 cache
- › Double-Precision Floating-Point Unit (FPU)
- › Integrated AltiVec unit
- › Up to 256 MB soldered NOR flash
- › Up to 4 GB NAND flash
- › Two UARTs
- › Wind River VxWorks BSP
- › QNX Neutrino BSP
- › Green Hills INTEGRITY BSP
- › Linux BSP

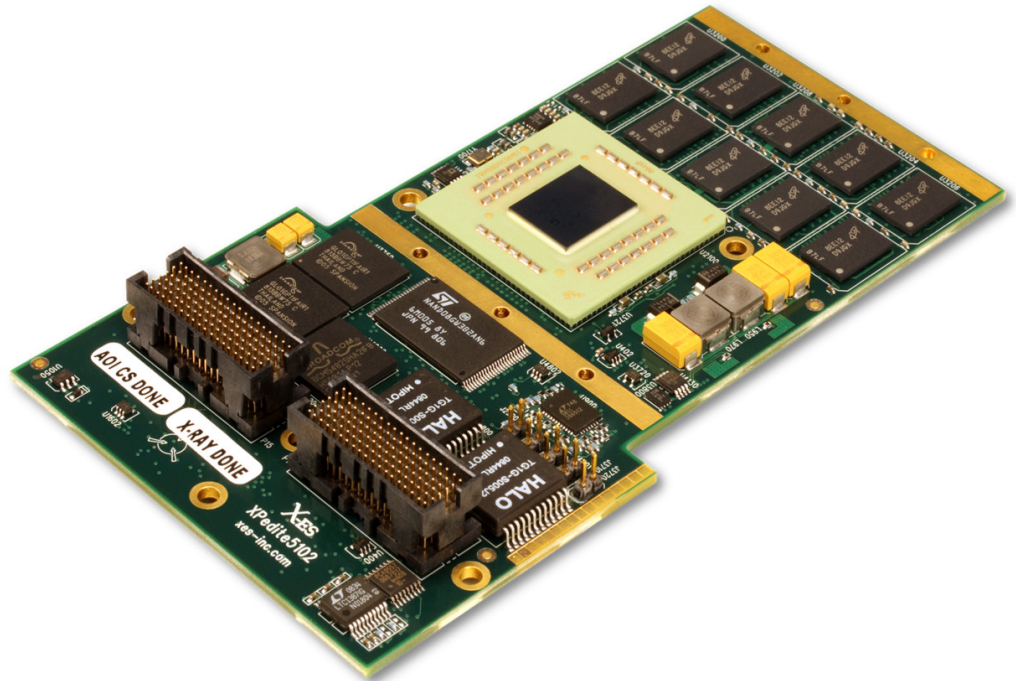

## XPedite5102

The XPedite5102 is a high-performance, short-form XMC featuring the Freescale MPC8640D processor. With dual PowerPC e600 cores running at up to 1.25 GHz, the processor delivers enhanced performance with AltiVec technology and IEEE 754 Double-Precision Floating-Point Unit. The onboard processor provides dual-channel DDR2-533 SDRAM, PCI Express, and dual Gigabit Ethernet interfaces, making the XPedite5102 an optimal solution for both communications processing and general computing applications.

The XPedite5102 provides two PCI Express ports on the XMC connectors to supply more I/O support without the cost of a switch. With software supplied by Extreme Engineering Solutions, the XPedite5102 can be installed on standard VME and CompactPCI (cPCI) platforms as well as custom motherboards that support XMC sites.

The XPedite5102 provides two Gigabit Ethernet interfaces and two RS-232/422/485 serial ports conforming to the VITA 42.10 pinout on P16.

# X-ES

Extreme Engineering Solutions

*...Always Fast*

### Extreme Engineering Solutions

3225 Deming Way, Suite 120 • Middleton, WI 53562  
 Phone: 608.833.1155 • Fax: 608.827.6171  
 sales@xes-inc.com • <http://www.xes-inc.com>

**Processor**

- Freescale MPC8640D processor
- Embedded PowerPC processor with dual e600 cores at up to 1.25 GHz
- 2.3 MIPS/MHz
- 32 kB L1 instruction/data caches
- 1 MB L2 cache per e600 core
- Double-precision Floating-Point Unit
- Integrated MMU
- Dual x8 PCI Express
- Four 10/100/1000BASE-T, IEEE 802.3-compliant Ethernet controllers
- Two serial controllers
- Two I<sup>2</sup>C controllers
- Integrated AltiVec unit

**Memory**

- Up to 4 GB of DDR2-533 SDRAM in two channels
- Up to 256 MB NOR flash
- Up to 4 GB NAND flash
- 16 kB SEEPROM

**XMC**

- x8 PCI Express (VITA 42.3) on P15
- Dual x4 PCI Express on P16
- IPMI support
- GPIO on user data

**RTC**

- M41T00 I<sup>2</sup>C Timekeeper
- 60 hour clock retention

**Rear Panel I/O**

- Two Gigabit Ethernet ports
- Four GPIO pins
- Two RS-232/422/485 serial ports
- VITA 42.10 compliant P16 pinout

**Software Support**

- Wind River VxWorks BSP
- QNX Neutrino BSP
- Green Hills INTEGRITY BSP
- Linux BSP

**Physical Characteristics**

- XMC short form factor
- Dimensions: 139 mm x 74 mm, 10 mm stacking height

**Environmental Requirements**

Contact factory for appropriate board configuration based on environmental requirements.

- Supported ruggedization levels (see chart below): 1, 3, 5
- Conformal coating available as an ordering option

**Power Requirements**

MPC8640D at 1.067 GHz, DDR2-533, all interfaces active

- 30 W per board

Ruggedization Level	Level 1	Level 3	Level 5
Cooling Method	Standard Air-Cooled	Rugged Air-Cooled	Conduction-Cooled
Operating Temperature	0 to +55°C ambient (300 LFM)	-40 to +70°C (600 LFM)	-40 to +85°C (board rail surface)
Storage Temperature	-40 to +85°C ambient	-55 to +105°C ambient	-55 to +105°C ambient
Vibration	0.002 g <sup>2</sup> /Hz, 5 to 2000 Hz	0.04 g <sup>2</sup> /Hz (maximum), 5 to 2000 Hz	0.1 g <sup>2</sup> /Hz (maximum), 5 to 2000 Hz
Shock	20 g, 11 ms sawtooth	30 g, 11 ms sawtooth	40 g, 11 ms sawtooth
Humidity	0% to 95% non-condensing	0% to 95% non-condensing	0% to 95% non-condensing

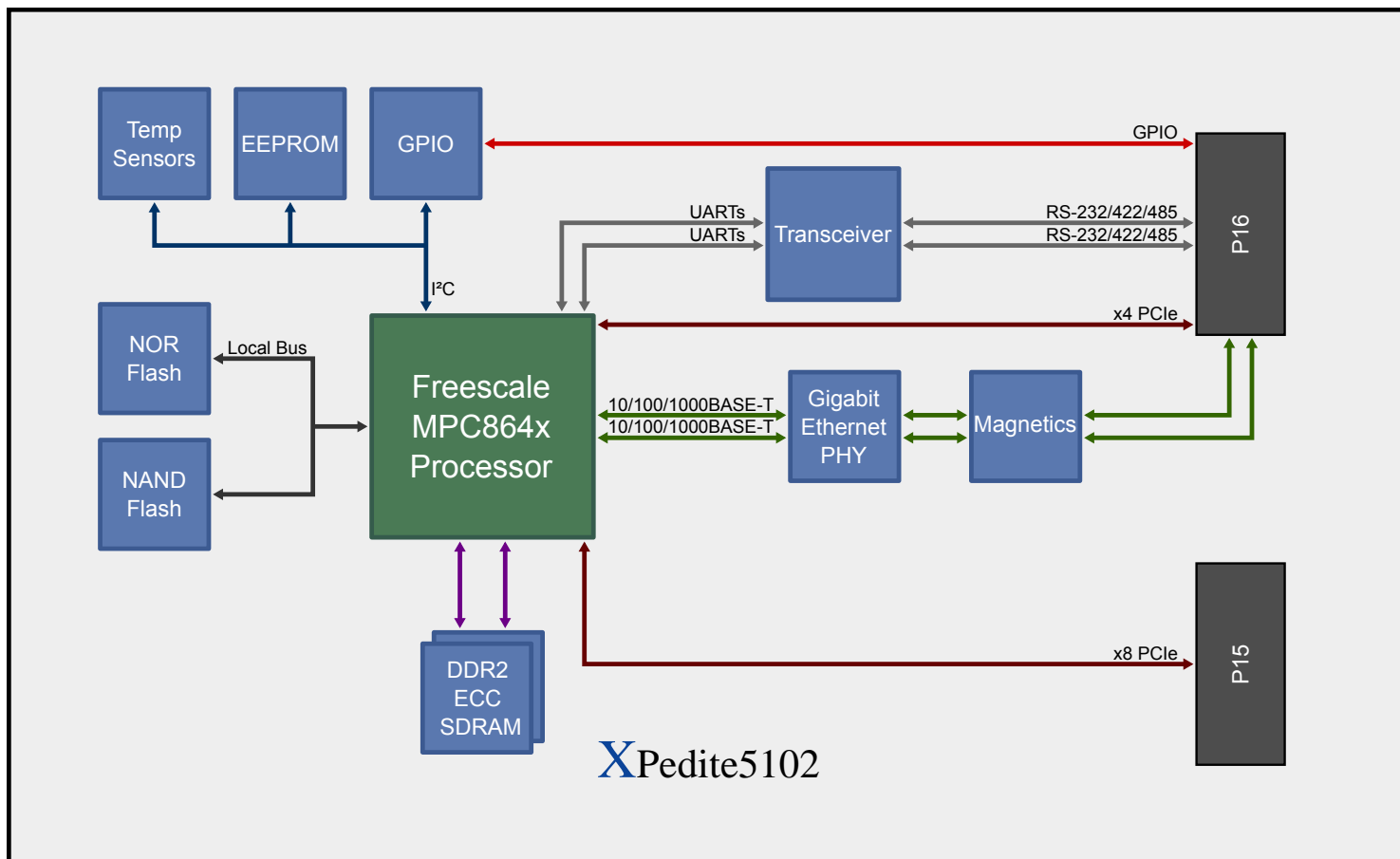

XPedite5102